

THIS DRAWING IS UNPUBLISHED. RELEASED FOR PUBLICATION
 © COPYRIGHT BY TYCO ELECTRONICS CORPORATION. ALL RIGHTS RESERVED.

DESIGNED FOR USE WITH
 RG-188A/U FLEX CABLE
 CABLE ENTRY DIAMETER
 MINIMUM

FERRULE	.125
CONTACT	.025
HOUSING	.066

LOC		DIST		REVISIONS			
AJ	00	P	LTR	DESCRIPTION	DATE	DWN	APVD
		B		REV PER ECO 07-004710	3/9/2007	DW	KW

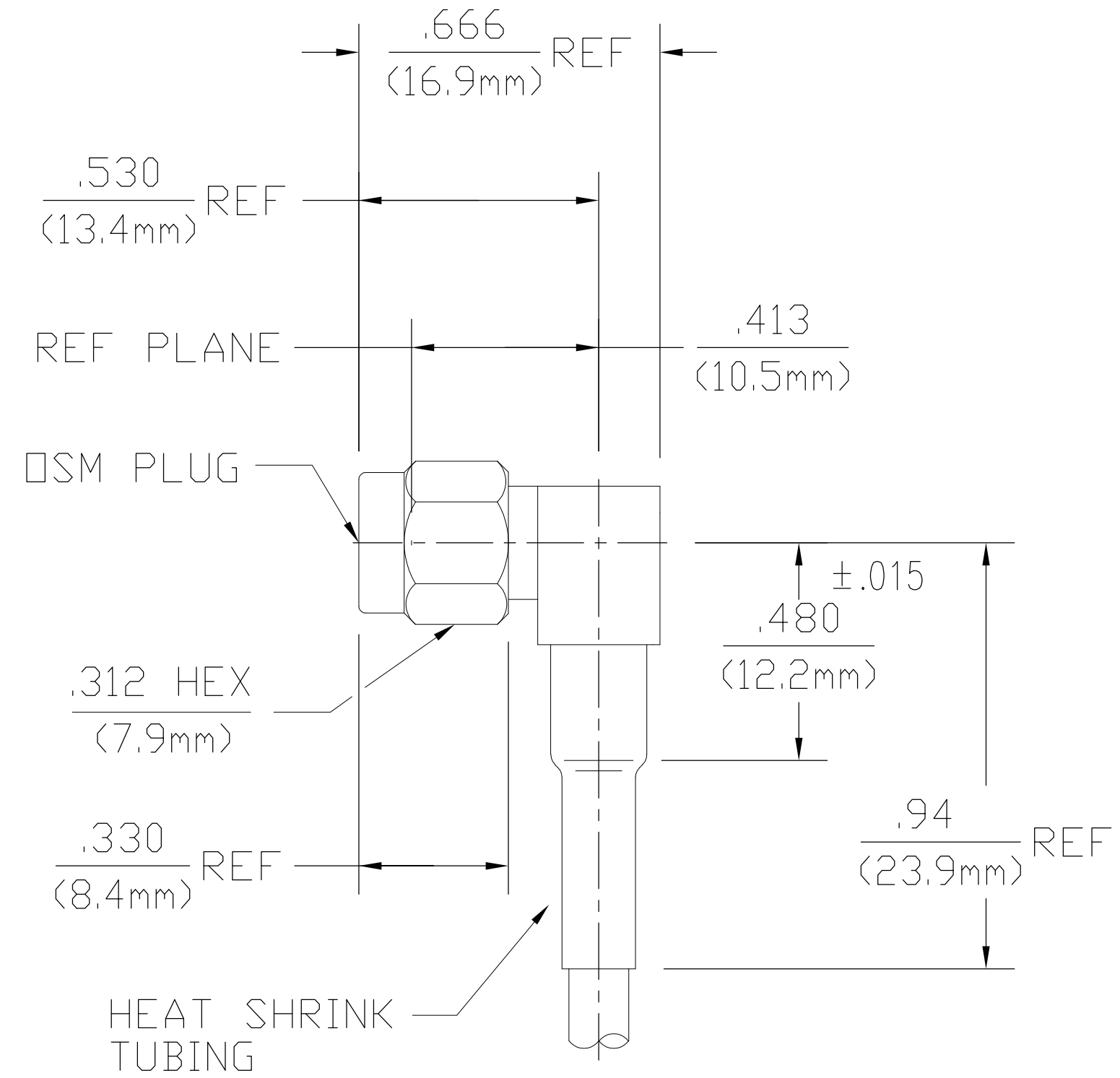

1052075-1
 PART NUMBER

HOUSING COUPLING NUT CAP	STAINLESS STEEL PER ASTM-A484 AND ASTM- A582, TYPE 303	GOLD PLATE PER MIL-G-45204 OVER NICKEL PLATE PER QQ-N-290
DIELECTRIC	TFE FLUOROCARBON PER ASTM-D-1457	N/A
CENTER CONTACT	BERYLLIUM COPPER PER ASTM B 196, ALLOY C17300, CONDITION H OR BRASS PER ASTM-B-16	GOLD PLATE PER MIL-G-45204 OVER COPPER PLATE PER MIL-C-14550
RETAINING RING	BERYLLIUM COPPER PER ASTM B 194, ALLOY C17200, CONDITION H	N/A
GASKET	SILICONE RUBBER PER ZZ-R-765	N/A
SHRINK TUBING	HEAT SHRINKABLE POLYOLEFIN COMPOUND MIL-I-23053/4	N/A
FERRULE	COPPER OR BRASS ALLOY ROCKWELL F65 MAXIMUM	GOLD PLATE PER MIL-G-45204 OVER COPPER PLATE PER MIL-C-14550
COMPONENT	MATERIAL	FINISH

ELECTRICAL	MECHANICAL	ENVIRONMENTAL
Nominal Impedance (Ohms) 50	Interface Dimensions MIL-STD-348A, Fig. 310.1	TEMPERATURE RATING -65°C TO +125°C
Frequency Range (GHz) DC to MAX	Recommended Mating	Vibration MIL-STD-202, Method 204, Condition D
Operating Frequency of Cable per MIL-C-17	Torque 7-10 In-Lbs	Shock MIL-STD-202, Method 213, Condition I
Volt Rating (VRMS MAX) @ Sea Level 250	Mating Characteristics:	Thermal Shock MIL-STD-202, Method 107, Condition B, EXCEPT HIGH TEMP +85°C
VSWR 1.18+.02F(GHz)	Insertion (MAX Lbs) N/A	Moisture Resistance MIL-STD-202, Method 106
Insertion Loss (dB MAX) .07√F(GHz)	Withdrawal (MIN Oz) N/A	Corrosion - MIL-STD-202, Method 101, Condition B, 5% salt spray
RF Leakage (dB MIN) -(60-fGHz)	Force to Engage and Disengage (In-Lbs MAX) 2.0	
Corona, 70,000 Ft (VRMS MIN) 190	Center Contact Captivation	
Dielectric Withstanding Voltage (VRMS MIN) @ Sea Level 750	Axial (Lbs) 6.0	
Contact Resistance (Milliohms MAX)	Radial (In-Oz) 4.0	
Center Contact 3.0	Cable Retention	
Outer Contact 2.0	Axial Force (Lbs) 20 Min	
Cable to Housing 0.5	Torque (In-Oz) N/A	
RF High Potential @ Sea Level (VRMS MIN @ 5 MHz) 500	Weight (Grams) 4.2	
I.R.(Megohms MIN) 10,000		

THIS DRAWING IS A CONTROLLED DOCUMENT.

DWN	EJC	5/22/66
CHK	BKW	5-24-68
APVD	CD	5-24-68

tyco
Electronics Tyco Electronics Corporation
 Harrisburg, PA 17105-3608

NAME: OSM RIGHT ANGLE CABLE
 PLUG-CRIMP ATTACHMENT

SIZE: A2 CAGE CODE: 00779 DRAWING NO: 1052075 RESTRICTED TO: -

MATERIAL: - FINISH: - WEIGHT: -

CUSTOMER DRAWING SCALE: 2:1 SHEET: 1 of 1 REV: B